

The set consists of four relay outputs receiver and one hand-held transmitter designed for use in radio remote control and access control. The system uses *KEELOQ*® (*) dynamic code technology and the receiver operates with all Elmes Electronic made 433,92MHz band transmitters and wireless detectors.

Operation

Activating transmitter stored in receiver memory results in setting on respective relay output. Depending on user programming, as described in sub-close 2 of the programming procedures, two modes of the receiver's relay outputs operation are possible: temporary output set on lasting from 0.5s up to 4h on each signal received from transmitter and bistable outputs set on in on-off (latched) mode activated by consecutive signals received from the transmitter.

Cross table below shows possible signal output S (OC type) operation modes selected by jumpers JP1 and JP2:

JP1 ON	JP2 ON	JP2 OFF
JP1 OFF	Two grounding pulses are generated at output S on any relay set, one grounding pulse – on any relay reset	Output S is permanently grounded if any of learned transmitters signals low battery
JP1 ON	Grounding pulses are generated for channel 1 output relay set/reset only	

JP3 – timing of grounding pulses at output S (jumper ON – 0.25/0.25s, jumper OFF – 0.5/0.5s).

JP4 – setting this jumper OFF allows **mini alarm control panel function** of the CH4H receiver – see detailed instructions further.

LED indication – lights green on all outputs off, lights red on any output on, blinks – when battery warning is on in any channel, as described below.

Low battery monitoring. This function is supported for Elmes Electronic transmitters type PTX50, GBX, CTX and RP. Blinking receiver's LED indicates detected low battery in one of the transmitters. Number of blinks in series corresponds to channel number where low battery is detected. Additionally, output S is grounded if jumper JP2 is set off. Low battery warning sets off after battery is replaced and transmitter activated.

Anti-sabotage protection (TAMPER). Opening of the CH4H receiver's housing is detected as TAMPER circuit break-in.

Installation (as shown on fig.1)

The CH4H receiver is designed to operate indoors with ambient temperature range from 0 to +40°C. Place of installation should be dry and away from any electromagnetic power lines, radio transmitters, metal screening and other devices that may cause interference and reduce operation range. Receiver should be installed 2 to 3 metres above floor level. Practical operating range test using optional Elmes Electronic RMF3 monitor is recommended prior to firm installation. Receiver's wire antenna should be let loose downwards and not glued to any surface. Receiver's outputs standby mode (NO-normally opened or NC-normally closed) are selected by jumpers, individually for each output.

Specifications

433,92MHz band receivers and transmitters.

Four galvanic separated relay output channels: Rec. CH4Hhet outputs rated 1A/30VDC or 0,5A/125VAC; Rec. CH4H outputs rated 1A/30VDC or 1A/120VAC; Optional outputs rated 1A/230VAC on order. Output S rated 1A/60V max.

Outputs pulse operating mode timing: 0,25 second to 4 hours.

Receiver power supply: 12VDC, 20mA standby, 120mA max.

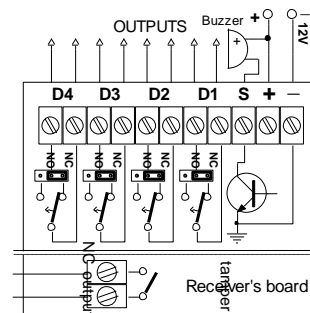

Fig.1

Manufacturer's Limited Warranty: this product carries one year warranty as from the date of purchase. The warranty is limited to the replacement of faulty original parts or repair defects of improper manufacture. Damage, faulty use or improper handling by the user or installer as well as any changes in product's hardware or software caused by the user violets the warranty and all due repair costs will be charged. Elmes Electronic shall not bear liability for any personal or material damage resulting from any of its products direct, indirect or partial failure to operate properly.

(*) *KEELOQ*® is a registered trademark of Microchip Technology Inc., USA.

WIRELESS ALARM CONTROL PANEL OPERATING MODE OF CH4H RECEIVER

When **JP4** is set off the Elmes Electronic CH4H receiver operates in wireless control panel mode (Fig.2 - connections diagram) featuring the following specifications:

- 8 wireless alarm zones for up to 40 Elmes Electronic wireless detectors and hand-held transmitters,
- arming and disarming by learned Elmes Electronic hand-held transmitter,
- alarm events memory (also on power cut off) with alarm zone indicated by LED,
- „panic” alarm function – hold pressed hand transmitter button for more than 2s,
- four relay outputs NO/NC type (jumper selected) for the following operation:
 - output D1 – armed/disarmed signaling,
 - output D2 – any application, sample: set on/off with 2nd button of two channel transmitter,
 - output D3 – optical and/or audible alarm signaling,
 - output D4 – 24h alarm zone (detector's sabotage TAMPER alarm or panic button function),
- audible signal control output OC type (open collector - 1A/60V) active on:
 - system arming (one pulse), disarming (two pulses),
 - alarm event recall from memory – 6 short pulses on disarming of the system,
- bicolor LED featuring system warning and indication:
 - system armed - lights red, disarmed – lights green,
 - alarm event mem. - flashes red when the system is armed, and up to 2 minutes after disarming,
 - alarm detector's low battery warning - flashes green when the system is disarmed,
 (number of flashes (1..8) indicates alarm event zone number or detector's low battery zone),
- on system armed number of audible alarms is limited to five,
- non-volatile memory of system status armed/disarmed on power supply cut off.

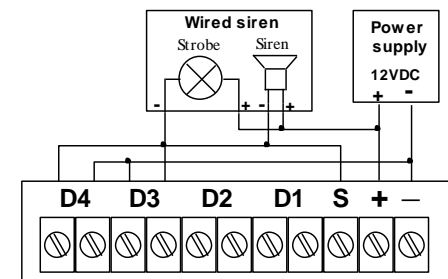

Fig.2

Steps to follow in design of a simple wireless alarm system with the use of CH4H receiver as control panel:

1. Set jumper JP4 off. Erase memory of the receiver according to programming procedures.
2. Set alarm channel to 1 in all detectors with alarm channel selector, close detector's boxes and program all detectors one by one to channel 3 of the receiver. The first programmed detector corresponds to zone 1, second to zone 2, ...eighth to zone 8, while the ninth again to zone 1. Up to 40 wireless detectors, 5 in each of the 8 zones of the system may be programmed this way
3. Program one channel Elmes Electronic hand transmitters to channel 1 used for arming and disarming of the system. Two channel hand transmitters can also arm/disarm the system: one button is used for arming/disarming and the other for controlling any other wireless appliance connected to output channel 2, for example opening a garage gate. Programming two channel use second channel button. It will control channel 2 while the first channel button will be programmed to channel 1 automatically.
4. Set the „on/off” (latching) output relay mode for output channel 1 and the required alarm timing (from 1s to up to 4 hours) in output channels 3 and 4.

Schematic diagram at Fig.2 above shows sample of basic alarm system with CH4H receiver as control panel (with learned detectors), wired outdoor siren & strobe and power supply 12VDC (minimum 120mA + required siren current). Channels 3 and 4 with selected NO output mode.

PROGRAMMING PROCEDURES

Programming is made with CH4H receiver front panel taken off and the use of programming PRG switch on the receiver's board.

1. LEARNING HAND-HELD AND OTHER TRANSMITTERS TO RECEIVER'S MEMORY (maximum 40):

Before entering this programming mode it is recommended to determine which hand transmitter's button or RP501 transmitter's input should control which output channel of the receiver.

Step 1. Press receiver's PRG switch for less than 2 seconds. Receiver's central LED switches to red and channel no 1 LED will illuminate,

Step 2. Shortly pressing the PRG switch (for less than 2 seconds) selects the required output channel for the transmitter,

Step 3. Press the PRG switch for more than 2 seconds, so as the main receiver's LED changes to green,

Step 4. Depending on type of transmitter to be learned proceed as follows:

- **hand-held transmitter** – double press transmitter's button. With multi channel transmitters double press button number respective to number of output channels required to be controlled, as in examples below:

Example 1: double pressing button 4 of hand transmitter CH4H with receiver's channel output 4 selected at step 2 above will learn all four buttons to the receiver. Now, button 4 controls output 4, button 3 controls output 3, button 2 controls output 2 and button 1 controls output 1.

Example 2: double pressing button 3 of hand transmitter CH4H with receiver's channel output 4 selected at step 2 above will learn first three buttons to the receiver. Now, button 3 controls output 4, button 2 controls output 3, button 1 controls output 2. Button 4 of this transmitter will not be active for this receiver.

Example 3: double pressing button 4 of hand transmitter CH4H with receiver's channel output 2 selected at step 2 above will learn two last buttons to the receiver. Now, button 4 controls output 2 and button 3 controls output 1. Buttons 1 and 2 of this transmitter will not be active for this receiver.

- **wireless detectors PTX50, CTX3H, CTX4H, GBX** – activate transmissions as described in detectors' manuals. Except for detector GBX, all other detectors' boxes must be closed!
- **RP501 transmitter** – set the transmitter's required mode of operation and activate transmission by disconnecting any of its inputs from the ground.

Receiver's LED blinking green slowly indicates end of procedure. LED's blinking fast red indicates programming error and the procedure must be repeated.

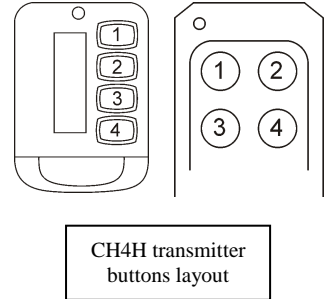

2. SETTING RECEIVER'S RELAY OUTPUTS TIMING IN PULSE OPERATION (monostable mode):

Step 1. Press receiver's PRG switch for more than 2 and less than 8 seconds, LED switches to red and again to green indicating entering this programming mode (channel no 1 LED is on and ready for programming set time),

Step 2. Shortly pressing the PRG switch (for less than 2 seconds) select the required channel,

Step 3. Press PRG switch for more than 2 seconds until the receiver's LED switches to red,

Step 4. Press PRG switch and the receiver's LED switches to green indicating **start** of the channel output set on time counting. When required set on time has lapsed (maximum 4 hours) press the PRG switch again to **stop** the procedure – LED switches to red.

After a short while receiver's LED blinking green confirms end of the procedure.

3. SETTING RECEIVER'S RELAY OUTPUTS TO ON/OFF (LATCHED) OPERATION (bistable mode):

Steps 1,2,3. Follow programming steps exactly the same way as in setting monostable operation mode in procedure number two above.

Step 4. Triple press shortly PRG switch with less than two seconds intervals. After a short while receiver's LED blinking green confirms end of the procedure.

4. DELETING ALL HAND-HELD AND OTHER TRANSMITTERS FROM RECEIVER'S MEMORY:

Keep pressed receiver's PRG switch for more than 8s. Initially, the receiver's LED switches to red and after two seconds to green. After next six seconds the LED starts blinking. Release the switch. The transmitters' memory of the receiver is now cleared, however channels' programmed modes of operation remain unchanged. The receiver will not respond any more to signals sent from any transmitters.

To learn new transmitter(s) to the receiver's memory follow procedure 1. To change output channels operating mode follow procedure 2 or 3 above.

5. DELETING SINGLE TRANSMITTER FROM RECEIVER'S MEMORY:

Except for RP501 transmitters, it is possible to delete any other single transmitter from receiver's memory under condition that the transmitter to be deleted is in our possession. This tricky procedure requires performing steps 1,2,3 of transmitter's learning procedure 1 above, whereas two succeeding transmissions at step 4 (double pressing transmitter's button) to be performed in the following way: first transmission must be sent from the transmitter to be deleted and second transmission from any other transmitter (e.g. by pressing other button in multi channel hand held transmitters). Receiver's LED blinking red will indicate programming error – in this case meaning that the transmitter is deleted. The receiver will not response any more to signals sent from deleted transmitter.

NOTE! Programming errors and no programming activity longer than 30 seconds are indicated by fast blinking LED in red, after which the programming mode sets off automatically.